

Stud ends and tapped holes with pipe thread, for use
with compression couplings, valves and screw plugs
Dimensions

DIN
3852-2

ICS 23.040.01

Supersedes
November 1991 edition.

Einschraubzapfen, Einschraublöcher, für Rohrverschraubungen,
Armaturen, Verschlusschrauben mit Whitworth-Rohrgewinde –
Konstruktionsmaße

In keeping with current practice in standards published by the International Organization for Standardization (ISO), a comma has been used throughout as the decimal marker.

Foreword

This standard has been prepared by the *Arbeitsausschuss Rohrverschraubungen* (Compression Couplings Standards Committee).

Amendments

This standard differs from the November 1991 edition as follows:

- Dimensions have been harmonized with those specified in ISO/DIS 1179-1 and ISO/DIS 1179-4.
- Type E stud ends are no longer specified.
- The standard has been editorially revised.

Previous editions

DIN 3852-2: 1953x-08, 1964-10, 1991-11.

All dimensions are in millimetres.

1 Scope

This standard specifies the dimensions and designation for stud ends and tapped holes with pipe thread for use with compression couplings, valves and screw plugs.

The dimensions comply with those given in ISO 1179-1 and ISO 1179-4.

2 Normative references

This standard incorporates, by dated or undated reference, provisions from other publications. These normative references are cited at the appropriate places in the text, and the titles of the publications are listed below. For dated references, subsequent amendments to or revisions of any of these publications apply to this standard only when incorporated in it by amendment or revision. For undated references, the latest edition of the publication referred to applies.

DIN 3858	Pipe threads for compression couplings – Parallel internal threads and metric taper external threads – Thread dimensions
ISO 228-1 : 1994	Pipe threads where pressure-tight joints are not made on the threads – Part 1: Dimensions, tolerances and designation
ISO/DIS 1179-1 : 1995	Connections for general use and fluid power – Ports and stud ends with ISO 228-1 threads with elastomeric or metal-to-metal sealing – Part 1: Threaded ports
ISO/DIS 1179-4 : 1995	Connections for general use and fluid power – Ports and stud ends with ISO 228-1 threads with elastomeric or metal-to-metal sealing – Part 4: Stud ends for general use only with metal-to-metal sealing (type B)

Continued on pages 2 to 6.

Translation by DIN-Sprachendienst.

In case of doubt, the German-language original should be consulted as the authoritative text.

3 Dimensions and designation

3.1 Stud ends

3.1.1 Types

Type A, with sealing by washer

Type B, with sealing by compression against face of body

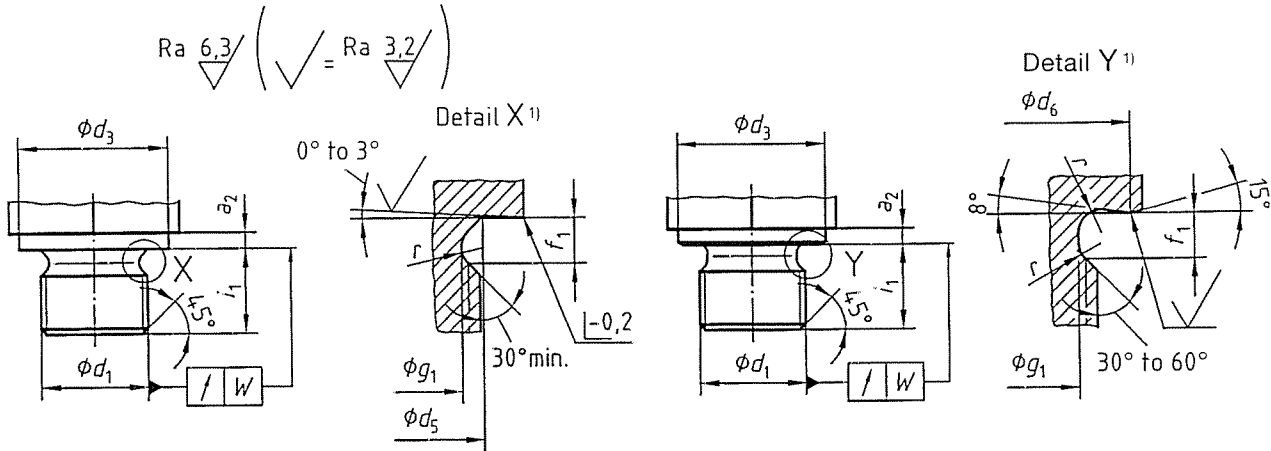

1) Thread chamfered to minor diameter.

Type C, with sealing in tapered thread

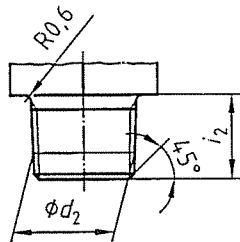

Figure 1: Stud end dimensions (notation)

Table 1: Stud end dimensions

Thread size for	a_2	$d_3^{1)}$		d_5	d_6	Groove dimensions		design		design		r	W
		Small	Large			f_1	g_1	Standard	Short	Standard	Short		
types A and B stud ends (d_1)	Min.	0 -0,4	Max.	0 -0,3	0 -0,5	+0,3 0	0 -0,2	With standard tapped hole only in compression couplings and valves	With standard and short tapped holes	With standard tapped hole only	With standard and short tapped holes	Min.	
								$\pm 0,2$					
G 1/8 A	1,5	14	18	10	13	2	8,3	8	8	8	6,5	1	
G 1/4 A	2	18	24	13,4	17	3	11,2	12	12	12	10	1,2	0,1
G 3/8 A	2,5	22	27	17	21	3	14,7	12	12	12	10	1,2	
G 1/2 A	3	26	33	21,3	25	4	18,4	14	14	14	12	1,2	
G 3/4 A	3	32	41	26,7	30	4	23,9	16	16	16	12	1,2	
G 1 A	3	39	46	33,5	37	5	29,9	18	16	16	14	1,6	
(G 1 1/8 A) ²⁾	3	44	50	38,2	42	5	34,6	20	16	16	-	1,6	
G 1 1/4 A	3	49	57	42,2	47	5	38,6	20	16	16	-	1,6	
(G 1 3/8 A) ³⁾	3	51	56	44,6	49	5	41	22	-	-	-	1,6	0,2
G 1 1/2 A	3	55	64	48,1	53	5	44,5	22	16	16	-	1,6	
(G 1 3/4 A) ³⁾	3,5	62	68	54	60	5	50,4	24	20	20	-	1,6	
G 2 A	3,5	68	75	60	-	5	56,3	24	20	20	-	1,6	

1) Where sealing is by compression against the face, d_3 shall preferably be small.

2) Type C stud ends with i_2 of the short design shall be provided with a taper screw thread with a useful thread of short length, with the thread length being in compliance with the specifications for taper screw threads given in DIN 3858.

3) The sizes given in brackets shall not be used in pipework applications.

3.1.2 Screw threads

Type A stud ends shall be provided with a pipe thread as in ISO 228-1, tolerance class A. Type C stud ends shall be provided with a pipe thread as in DIN 3858, tolerance position 1 (for standard design), or tolerance position 2 (for short design).

3.2 Tapped holes

Types X and Y tapped holes are intended for use with types A and B stud ends.

3.2.1 Types

Type X, with run-out

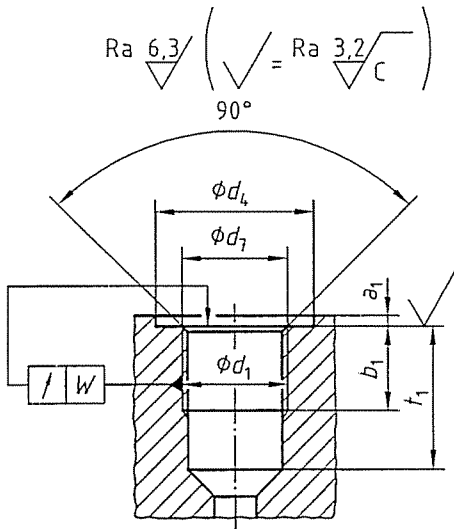

Type Y, with groove

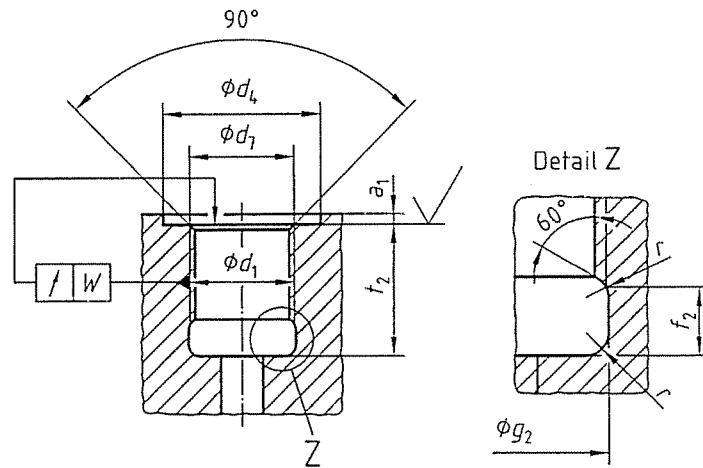

Type Z tapped holes are intended for use with type C stud ends. Thread countersunk to dimension d_1 .

Type Z, with run-out

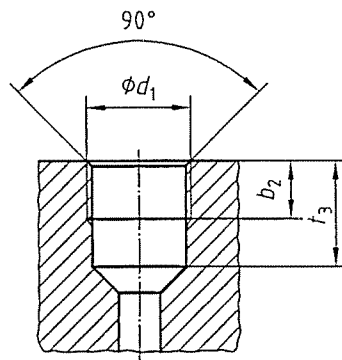

Figure 2: Tapped hole dimensions (notation)

Table 2: Tapped hole dimensions

Thread size (d_1) for	a_1	Stand-ard design		d_4 ^{1),2)}	Groove dimensions		Stand-ard design	Stand-ard design	Stand-ard design	Stand-ard design	Stand-ard design	W		
		b_1	b_2		f_2	g_2							r	t_1
types X and Y tapped holes	Max.	for stand- ard and short stud ends	for stand- ard and short stud ends only	Small Large	Lim. dev.	Stand-ard design	Stand-ard design	Minimum	Minimum ³⁾	Minimum	Minimum			
G 1/8	1	8	6	15	9,8	3	2	9,9	1	10	8	8	8,5	6,8
G 1/4	1,5	12	9	20	13,2	4	3	13,4	1,2	15	12	12	12,5	10,5
G 3/8	2	12	9	23	16,7	4	3	16,9	1,2	15	12	12	12,5	10,5
G 1/2	2,5	14	12	28	21	6	4	21,2	1,2	18	16	16	16,5	13,5
G 3/4	2,5	16	12	33	26,5	6	4	26,7	1,2	20	16	16	19	15,5
G 1	2,5	18	14	41	33,3	8	5	33,5	1,6	23	19	19	-	16,5
(G 1 1/8) ³⁾	2,5	20	14	45	37,9	8	5	38,1	1,6	25	19	19	-	-
G 1 1/4	2,5	20	14	51	42	8	5	42,1	1,6	25	19	19	-	16,5
(G 1 3/8) ³⁾	2,5	22	14	52	44,4	8	5	44,6	1,6	27	19	19	-	-
G 1 1/2	2,5	22	14	56	47,9	8	5	48,1	1,6	27	19	19	-	16,5
(G 1 3/4) ³⁾	3	24	14	63	53,8	8	5	54	1,6	29	19	19	-	-
G 2	3	24	14	69	59,7	8	5	59,9	1,6	29	19	19	-	-

1) Where sealing is by compression against the face, d_1 shall preferably be of the small design.

2) The counterbore (d_4) may be dispensed with where no washer is used and where the contact face is flat and normal to the thread axis.

3) The sizes given in brackets shall not be used in pipework applications.

3.2.2 Screw threads

Types X and Y tapped holes shall be provided with a pipe thread as in ISO 228-1, and type Z tapped holes with a parallel internal thread as in DIN 3858.

4 Designation

The designation of stud ends and tapped holes conforming to this standard shall include the following items, given in the order below:

- a) name ('stud end' or 'tapped hole');
- b) DIN number ('DIN 3852');
- c) symbol denoting type (cf. figures 1 and 2);
- d) symbol 'K' to denote the short design (no symbol being necessary in the case of standard designs);
- e) symbol 'B' to denote large design of shoulder or counterbore (no symbol being necessary in the case of small designs);
- f) symbol denoting thread size (e.g. 'G 1/2' for that designated G 1/2 A).

Designation of a type A stud end (A) of standard design, with small shoulder and with a thread of size G 1/2:

Stud end DIN 3852 – A – G 1/2

Designation of a type X tapped hole (X) of standard design, with small counterbore and with a thread of size G 3/4:

Tapped hole DIN 3852 – X – G 3/4

Designation of a type Z tapped hole (Z) of short design (K), with a thread of size Rp 3/8:

Tapped hole DIN 3852 – Z – K – R 3/8