



ELSEVIER

Computer-Aided Design 36 (2004) 1439–1450

COMPUTER-AIDED
DESIGN

www.elsevier.com/locate/cad

Engineers' CAx education—it's not only CAD

C. Werner Dankwort, Roland Weidlich*, Birgit Guenther, Joerg E. Blaurock

*University of Kaiserslautern, Research Group for Computer Application and Engineering Design, P.O. Box 3049,
Kaiserslautern 67663, Germany*

Received 30 January 2004; accepted 23 February 2004

Abstract

The general product development can be divided into three phases: creative, conceptual and engineering phase. All phases of the complete life cycle of a product are supported by various IT-systems often called 'CAx'¹-systems. Therefore CAD-education should be extended to 'CAx-education' and pay attention to all phases of the life cycle.

When looking at today's process chain many different jobs related to CAx can be identified. All of them require different levels of knowledge about subjects like information technology, design procedures or CAGD²-functionalities.

The methods to teach those subjects vary from simple autodidactic, via computer supported training methods to interactive person to person training. In industry, the training methods are primarily depending on the company's size and branch. The bigger the company is, the more complex are the training methods and the more specialized is the CAx-education.

Enterprises specialised on CAx-training but also in-house education departments are concerned. Other possibilities for CAx-education are internships, technical colleges and universities. All of those suffer from the complexity of the subject and result often in broad but superficial education.

Apart from knowledge about CAx-systems and their usage, the students have to learn also about the organisation of the CAx-process and its structures including the cooperation of enterprises.

Following these experiences the students or employees will at first be trained in fundamental CAS/CAD/CAM. In a second step they will attend special courses for PDM, Data exchange, FEM, or others. On higher level there will be courses dealing with PLM³, process- and company networks, with future trends and techniques. During the whole education the application aspect has to be dominant.

© 2004 Elsevier Ltd. All rights reserved.

Keywords: CAx job profiles; Human factors; Training methods; CAx education in industry; CAx education in universities

1. Motivation

In a newsletter of the year 1999 from Solid Works the following question was raised: "What is the most important learning objective?" The answer given was "To teach that design is a process!" Later on in this newsletter it was said that engineering education is supposed to educate engineers in 'how to think in the modern world of product design and manufacturing' [1]

What does this mean for 'CAD-education' in industry, at schools and universities? It certainly does not mean that

'CAD-education' is only restricted to teaching 'solid or surface modelling'. The task is quite more complex: the student or technical employee has to learn about the complete development process under the aspect of Computer Aided Product Creation.

2. A brief history of CAD-systems

Modern CAx-systems have various roots:

- The Automatic Programming Tool (APT) developed by Ross at MIT in the 1950s to control machines numerically. This can be regarded as the precursor of modern CAM-systems.
- The early computer aided drafting systems (like CADAM from Lockheed Martin) were developed to

* Corresponding author. Tel.: +49-631-205-3686; fax: +49-631-205-3872.

E-mail address: weidlich@mv.uni-kl.de (R. Weidlich).

¹ CAx: Summarised CAD, CAM, CAS, CAQ,

² CAGD: Computer Aided Geometric Design

³ PDM: Product Data Management, PLM: Product Lifecycle Management

reduce time and money by replacing the conventional drawing board in the 1970s.

- The early systems for the creation of sculptured surfaces originally were developed for the automobile and the helicopter industry. The motivation for this development was not the reduction in time but a distinct 3D-representation of sculptured surfaces which then could be used for NC-milling. This 3D-surface representation could not be created with conventional 2D-drawings and cut sections.
- Computer Aided Engineering by Finite-Element-Methods began in the 1960s with Nastran, followed by Marc and Ansys in the 1970s.

From these roots more and more tasks in the design process were supported by CAx-tools during the last 30 years. Starting with drafting and surfacing also classical mechanical design was replaced by 3D wire frame, solid modelling and parametric and feature based design. Today the complete product creation process, including production preparation, is completely running with CAx-techniques. According to the various application fields different CAx-systems were developed, named by different CAx-methods: Computer Aided Styling (CAS), Computer Aided Aesthetic Design (CAAD), Computer Aided Conceptual Design (CACD). All these technologies are covered by the expression Computer Aided Design (CAD). Two very important CA-fields were historically developed almost independently: Computer Aided Manufacturing (CAM) and Computer Aided Engineering (CAE). The last is mainly used in a limited sense for simulation and Finite Element Analysis. Although starting

independently these technologies soon asked for input-data from CAD, I-DEAS, developed in the mid 1970s has its root in the link of CAD and FEA.

With the growing integration of these CAx-tools the data and information management became more and more important. Nowadays the complex network of CAx-systems and their various data cannot be handled without Product Data Management Systems (PDMS). They are regarded as the backbone of modern product development and now extended to support the whole product lifecycle. This overall information management leads to the concept of Product Lifecycle Management (PLM).

Education concerning ‘Computer Aided Product Creation’ still does reflect this history: Students or engineers usually start their education with 2D-systems. Subsequently they are introduced to 3D-modelling. Further on they are familiarized with parametric and variational design. Parallel they have to be trained in PDM- or PLM-systems to handle all the CAx-data.

3. Today’s process chain

In an exemplary simplified process chain (see Fig. 1) it is shown that CAD is only a part of the product development process. This process begins with an idea, requirements and specifications for the product and ends with the serial production, customer after sales service, recycling, scrapping and disposal. CAD is embedded in the development process together with many other CAx technologies. In order

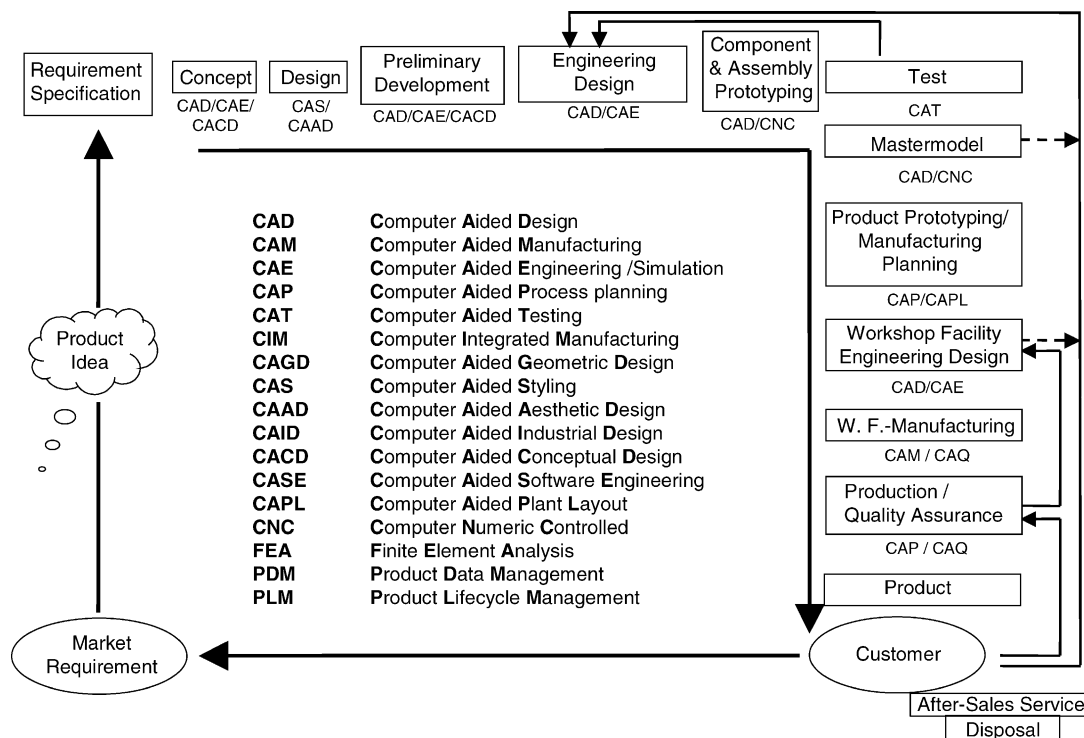

Fig. 1. General process chain of product development [2].

to avoid unnecessary loops the engineer has to have knowledge of the surrounding process steps as well as the kind and quality of data, respectively information, they produce or require. The knowledge about the previous process steps is to maintain the design intend, the knowledge about the following process steps is to guarantee their feasibility. In addition to this economical aspect the quality of the product describing information has to be taken into account.

The modern product creation process proceeds more and more as a ‘virtual product’ generation process. Keeping in mind that the processes are characterized by ‘Simultaneous Engineering’ (performing different process steps at the same time) and ‘Concurrent Engineering’ (developing neighbouring components in parallel), it is obvious, that an enormous amount of data produced has to be handled by an efficient product data management system (PDM). Two facts increase the complexity of the situation:

- For different tasks within one or various process steps sometimes quite different CAX-systems have to be used with quite different data models.
- In modern industry a network of suppliers is involved, often working with different systems or different versions of the same system.

Therefore not only CAX-data exchange with data conversion is a key task for successful development and production processes but also the complete supplier integration.

4. ‘CAX people’: various job profiles

When looking at the history of CAD, the first users of CA-tools in the 1970s were CAD-draftsmen and CAD-surface designer for car bodies or helicopter shells (today often called ‘surfacers’). Already in the 1970s the surfaces were used directly for NC-milling of surfaces, while the FEA-engineer used the CAD-geometry as input.

Draftsman and surfacers were trained primarily by system suppliers and/or by an in-house CAD-technician. These CAD-technicians often have been pilot users, trainers, and in-house system supporters at the same time. These pioneers made the new technique presentable and reduced prejudices, which had been raised by the conventional development.

With the growing capabilities of the CAD-systems in the first half of the 1980s the number of different ‘CAD people’ grew. In the 1990s the scope of CAX-tools increased and today CAX-technology is more or less standard. Nowadays the intensive usage of CAX-technologies can be regarded as a precondition for any competitive company. As a consequence the various tasks cause various jobs. Following the process chain there are (see Fig. 1):

- Stylists, who work manually, sketching and modelling with clay, but also more and more with CAS-systems like ALIAS
- Surfacers, who transfer the shapes, designed by the stylists, to CA-Class-A-surfaces. They use special surface-systems like ICEM-Surf or in former times STRIM100.
- CNC-Model makers, who use CAM-techniques to generate physical models from CAS- or CAD-data. This is done to transfer the shapes from the ‘virtual world’ to the ‘physical world’.
- To fill the gap between a manually optimized physical model and the required CAD-surface description a special task is necessary: The surface reconstruction or ‘reverse engineering (of shapes)’

In the field of standard engineering design there are the CAD-designers or CAD-engineers, who are working with 3D-systems. According to their tasks, working fields and the level of CAD-application they are using wire frame techniques, surface-systems and/or solid modelling. Now, with introduction of more sophisticated design techniques and with the increasing information, which is stored in a CAD-model, many fields of CAD-applications and related special job profiles can be distinguished:

- *Component designers.* They are in charge of the design of special components of the product.
- Engineers for Parametric-Associative Design
- CAD-designers for tools and quality aids.
- Process planners
- Manufacturing simulators
- CA-plant lay-outers

Parallel to the CAD-design the simulation of product properties is another important task in the product development, which gives another job profile:

- Engineers for simulation, analysis and calculation. To generate reliable results they usually are highly specialized on certain tasks. Consequently this job profile could be further structured.

In former times these engineers for simulation often worked in isolated departments, starting the analysis when the design had been preliminarily finished. Nowadays these tasks are completely integrated in the design department and go along with the design. At the moment there is a tendency that the engineers perform a preliminary analysis within their CAX-system to evaluate their design.

This list of people and tasks involved in CAX can be continued, all of them need at least some CAX-knowledge:

- Specialists for CAX-graphics generation
- Clerks within the purchasing departments for arranging contracts between OEM and the subcontractors

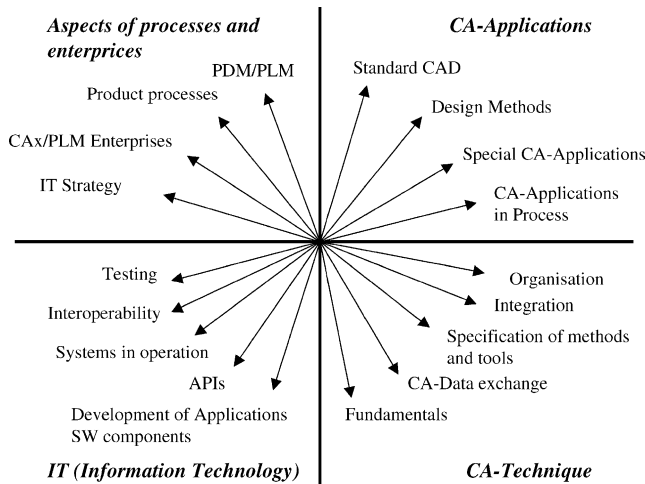

Fig. 2. Portfolio of the CA-landscape in an enterprise.

and suppliers.

- SW-design and SW-implementation
- Application SW definition
- CAX-systems in operation
- CAX-system testing and SW-quality control
- Computer centre and network operation
- Information management
- CAX-data exchange: development and operation of SW-tools

These examples show that there is a variety of different jobs, each needing different know-how in the different fields. Some examples are given in Fig. 2.

Industrial experts estimated, that for one CAD-workstation about 10 other workstations are used in subsequent activities like viewing etc. [3].

5. The 'Human Factor' and the environment

The different knowledge, which is needed for or which is gained in the different jobs, is one aspect. Another very important aspect in training people for their CAX-job is the 'human factor'. There are three points which have to be considered:

- The past, the education and the experience of a person
- The 'human potential', the ability to fulfil the tasks of modern product development with CAX- and Information Management tools.
- The environment in which a person has worked before and in which it is going to work next.

Each of the points above will be briefly described in the following, already showing the complexity of modern CAX-education and that there is nothing like a 'standardized CAD-education'.

5.1. The past, the education and the experience of a person

Each person has a different background and, as his/her mind is strongly influenced by it, the way of thinking and learning will be different from person to person. An example: In former times it was a strenuous task to make designers, who had worked many years at drafting tables, use a CAD-system efficiently. For them this meant to approach problems in a completely new way. But the experience, which was gained by solving problems the 'classical way', often got lost. It could not be transferred to young engineers, who started their career on CAD-systems.

This example shows one of the duties of CAX-education: To teach also some design methods used in former ('pre-CAD'-) time to make users aware of different ways of thinking and of approaching problems in order to avoid risks like: The restriction of the 'thinking' to the limits given by the capability of the IT-tool in use.

5.2. The 'human potential'

This second aspect is more sensitive than the first one. It is fact, that not all people have the same creativity, efficiency and flexibility. Much research has been done on this matter, but it will go far beyond the scope of this paper to go into details here. The relation between number of people on one side and 'skill, potential' on the other side is often similar to the classical Gaussian distribution (see Fig. 3) [4]. People of high capability and efficiency should be related to the right hand side of such a distribution. Training them on a CA-system will take very short time and such students or employees will work with high productivity in a very short time. These are typical 'pilot-user', which are of highest importance for the break through of CAX-technology in companies.

Most of the engineers may be considered to be 'on the average'. Current group training methods usually focus on this majority. The effect will be, that some people in this large group are swamped by the speed and content of the training, while others are unchallenged by it. The praxis in industry shows that the demands on engineers for the modern parametric-associative design often cannot be fulfilled after standard training. But there are also people related to the left side of the Gaussian distribution, who need more efforts in training to become a CAX-engineer than the average. No standard procedure can be proposed here. But it

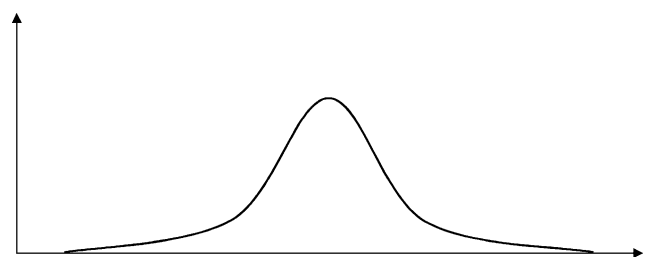

Fig. 3. The Gaussian distribution.

is a challenge on personnel leadership to find good solutions for anybody.

5.3. The environment

Additionally to the two points described before the environment of a CAx-user is important for his knowledge or training. The enterprise culture may support or prevent a person to show lack in knowledge, to ask someone for help. This aspect may be of more importance than technical facets, like different design standards in the different companies, e.g. of creating a CAD-model. Thus an engineer going into a new company for the same job not only has to be trained in new standards but also may be faced with a different kind of team culture.

6. Depth of the training and responsibility

The curriculum of the CAx-education can be divided into different fields of knowledge and into different specialisation of knowledge. The fields of knowledge are already shown in Fig. 2. The specialisation of knowledge means the relevance of a certain knowledge for a given task or job. In the following it is distinguished between three categories, analogue to the common terms of knowledge:

- General CAx-knowledge

This kind of CAx-knowledge is the basis for further specialized knowledge. Each person involved in modern CAx-technology should have this knowledge.

- Specialized CAx-knowledge

This knowledge is common to all the people working at a certain job. Every CAx-Designer working with the same software in the same branch should have the same specialised knowledge.

- Specialist CAx-knowledge

This knowledge highly depends on the actual job and the company the person belongs to. It is mostly connected to the structure and procedures which are common in this company. Specialist knowledge can be in-depth knowledge of certain software functions which are needed to perform highly specialised tasks. E.g. knowledge about quality assurance to provide the production with the right CAx-quality data can also be regarded as specialist knowledge.

The listing above already implies the responsibility for the different kinds of knowledge. (There is a difference between: Who is responsible-and-Who has to impart the knowledge.)

- Universities

The universities are in charge of the general CAx-knowledge. This includes technology and business operations as main topics:

- The overall perspective on the CAx-technology including history, trends, possibilities, unsolved

problems and fundamentals like the mathematics and basic IT-knowledge.

- The standard industry processes with respect of CAx-technology—including an overview on product data model technique, PDM, data exchange
- Principles of relations between companies: OEMs, suppliers and SW-vendors
- The standard design methods and procedures (see. e.g. Refs. [5,6]) in the view of CAx-technology
- The general handling of modern CAx-tools including an overview of the market and the fields of application
- A training on at least one common CAx-tool, to get practical experience in product design with CAx-technology.

- Companies

The companies are responsible for their employees, that they are able to be efficient in their work. This includes all necessary CAx-knowledge, which is called ‘specialised’ and ‘specialists’ knowledge. The CAx-training task a company will delegate to subcontractor or into special departments (see below). Of course some parts of specialists’ know-how remain, which will be imparted directly within the application departments during the running job:

- Special training with the CAx-tool, concerning the common practice in this particular department, used 3rd-party-tools and special company conventions.
- Training on the special procedures and structures which are related to this specific job.
- Training companies or training departments

Training enterprises or training departments in bigger companies are responsible for the specialised knowledge which includes:

 - Training for a job (e.g. CAx-designer for engines) with the specific CAx-systems. This also includes teaching of the best practice for common tasks, known problems and their workarounds.
 - Training to manage CAx-data in PDM/PLM systems. Huge companies often have special PDM/PLM systems, the use of them can also be taught by trainers, not necessarily employees of the mother-company. These external trainers are specialised for one company.
 - Interoperability and CAx-data exchange
- Software vendors

The Software vendors offer training as well, but often this training is not well suitable for training of application people in industry. This has several reasons:

- In SW-houses there is often a lack of expertise in the application with its processes, methods and resulting problems of the product creation.
- In most cases the clients of the SW-vendors belong to quite different industrial branches.
- Software vendors are not independent enough to make people aware of known software problems and useful

workarounds or to propose 3rd party solutions.

- The training material of SW-vendors is mostly IT-oriented and not well suitable for engineers.

The training job of software vendors can be summarised to ‘train the trainers’, which should include:

- New and extended functionalities of new software versions.
- General strategies and limitations of a given software
- System interoperability, interfaces for data access and programming

7. Training methods

Independent from the training contents, there are several training methods which differ in intensity and costs. These training methods can be combined in an effective way.

- Computer based Training

The cheapest way of CAx-training is the so called ‘Computer Based Training’ (CBT). Some CAx-system vendors offer special software for studying the CAx-system in an autodidactic way. But also enterprises specialised on CBT offer their solutions. Most of these CBT-programmes just show the handling and the functions of the program. Often there is a lack in teaching autonomous, independent work. Strategies to solve design problems can not be standardised. Furthermore this training method gives only little feedback about the success of the training. For example the student or engineer will not be informed whether his/her training part is right or wrong and why. Due to these deficiencies in the beginning the computer based training is not widely spread.

But the development of the CBT technique is in progress, more and more systems are able to learn by themselves, which means, that the experiences a (pilot-) user made, can be captured and will be available for future training. Systems, which can be customised to the needs of a special company are already available.

- Practical course (‘Face to face’)

A better, but more expensive way of CAx-Education is a practical course with instructor guidance. Main advantage is the direct feedback from the CAx trainer. Another advantage is the possibility to get explanations, if there are questions, unsolved design problems or curious behaviour of the CAx-system. A disadvantage is, that after the course is finished the trainer often is not available any longer.

- Follow-on coaching

Follow-on coaching is a way to solve the problem described above. If companies have an internal education department or a permanent external training staff in-house the guided training can be combined easily with intensive onsite follow-on coaching.

After the CAx-training is performed for and inside a special department, to meet the needs of the department, the trainer stays to provide further assistance.

- In-house ‘Hotline’

Many bigger companies operate in-house ‘Hotlines’, where users can ask for support on specific problems. This is especially helpful, if an engineer has difficulties with seldom used functionalities.

When looking at the costs of the different training methods it is inevitable to regard the overall costs, which are not only influenced by the costs of trainers, training equipment or necessary hardware to do training. The most important costs are due to the loss of capacity and efficiency of the co-workers during training and in the run-up period before getting full job performance. These costs can be between 2/3 and 3/4 of the overall education costs.

Therefore when looking for an adequate training method the total costs have to be regarded. Very often it is far more economical to send an engineer to an expensive training than to leave him with computer based training with the result of inefficient working over long term. (cf. also chapter 9.2)

8. The CAx-education in industry

A typical CAx-education of a new employee in a bigger company is shown in Fig. 4. It is based on guided training (eventually mixed with CBT), follow-on coaching and assistance.

CAx-Education in industry depends on the size of the company. (This paper mainly uses information from automotive industry.) Generally it can be said, that the bigger or the more specialised a company the more tailored CAx-training is. The OEMs in the automotive industry have many users and very different applications, thus the CAx-training is organized in a modular system. Training by internal and external trainers in a central education department is combined with inside-training in the various

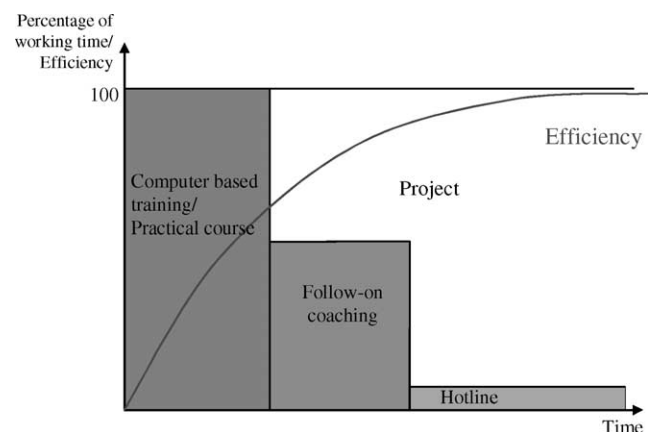

Fig. 4. A typical CAx-education and the efficiency of a new employee.

engineering departments. CBT completes this concept. For an efficient training the trainers have to have specialist knowledge of the job they are training people for. This leads to job rotation, where e.g. very good CAx-engineers become CAx-trainers to train the next generation of engineers.

8.1. Job rotation

In some automotive companies an ‘optimisation loop’ between product engineering, CAx-education and CAx-application support was introduced (see Fig. 5).

Here an organised job rotation is the base of deep understanding as well as up-to-date know-how of the persons working in these three departments. The information flow is carried by the people involved:

- From *Product Engineering* to *CAx-Education*: Product- and application know-how, design procedures, workflow information (medium term this change is related with an advancement)
- From *CAx-Education* to *CAx-Support*: Requirements on new functionalities, on improvements; information about problems and errors in functionalities; feedback about the usability of applications
- From *CAx-Support* to *Product Engineering*: Background of problems in functionalities; limitations based on principles of CAx-technology and/or on SW-bugs; complexity of SW operation.
- From *CAx-Education* to *Product Engineering*: In-depth knowledge about CAx-functionalities, hidden functional alternatives, improvement of design procedures (normally this change is combined with a coordinating position)
- From *CAx-support* to *CAx-Education*: Know-how about system-internal limitations (e.g. caused by the system architecture); functional by-passes.

But the most important effect on efficiency is the personal relation between the persons in the various departments. This helps to cope with difficulties during the product development process in a trouble-free, informal way. In a modern company job rotation of persons between

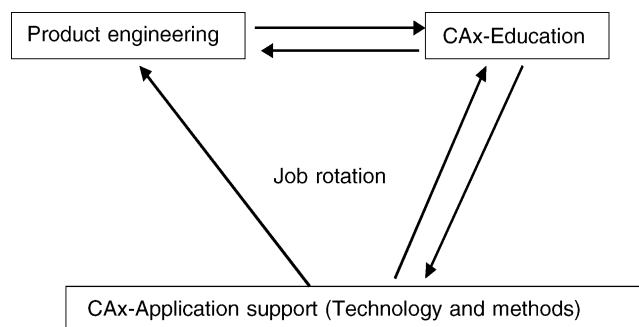

Fig. 5. Optimisation loop.

any departments is a usual means in human resources development. In this case the know-how transfer between departments is the most important advantage.

8.2. Efforts for and within CAx-education

In the automotive industry the costs and efforts for the software itself and its maintenance are not the main part of the CAx-costs. A big amount is caused by the CAx-education. To estimate these costs various factors have to be considered:

- *Direct costs*. Capacity of the trainer, computer, licenses, rooms,... Capacity for support during ‘training on the job’
- *Indirect costs*. Time off of the trained person, decrease of efficiency while training on the job.
- *The over-all economic balance*. CAx training has to bring a profit to the company. Thus the loss of labour time and efficiency, summed up over all the trainings periods, has to be compensated by the increased job performance after successful training.

These effects and costs differ for the different kind of CAx-education:

- Basic and advanced CAx-training
- Specialised courses
- Refresher training and training for changes of systems releases
- Training new system versions
- Training of management

A typical engineering department in automotive industry with about 300 CAx-engineers needs about 1–1.5 man-years for training and support per year. The average bounded engineering capacity is about 3–5% of the total capacity. That means another 9–15 man-years per year. This sums up to a total of about 10–16 man-years per year. This loss of capacity has to be regained by the higher efficiency of the better educated engineers or by the advantages of a new or improved CAx-system.

Of high uncertainty are the training and support efforts during the changes of the system versions. For the ongoing change from CATIA V4 to CATIA V5 in the automotive industry no figures regarding the efforts have been published, but the costs on training and support can be regarded as a big part of the total costs of the change.

9. Teaching horizon at universities

As already mentioned above, it is in the responsibility of the universities to impart the general CAx-knowledge to the students. The curriculum for engineers is normally limited in the number of hours for lectures and training.

Therefore not all subjects can be taught, which might be of interest for later industrial work.

That does not mean that students can not get profound CAx-knowledge during their studies beyond the formal curriculum. They can e.g. improve their CAx-know-how in various fields of interest by internships, voluntarily special courses, or work at university in research groups. What kind of knowledge and in which depth a student gains during his/her studies is in his/her responsibility. In most cases he/she has the opportunity to get voluntarily an extended CAx-education, including specialist knowledge in certain areas. This specialist knowledge may get vital for him/her, when applying for a job in industry.

During his/her studies the student should get good fundamentals for his/her future work. Since engineering has such a wide range, it is obvious, that the learning process will not end at the university. ‘Life long learning’ is the slogan. This holds especially for modern product development, which is based on classical and modern design methods as well as on fast changing CAx-technologies. Therefore the student has to be prepared for his/her future job, but the required specialist know-how he/she has to get in the job or parallel to it and has to update it as long as he/she is in professional life.

9.1. CAx fundamentals in design and workflow

The education for engineers should include both engineering techniques (like ‘machine elements’ etc.) and CAx-aspects. The various lecturers have to cooperate and to coordinate the content of their lectures.

A holistic view on the today’s industrial development and manufacturing process of products is the base of understanding the single steps like detail engineering design. Knowledge about the industrial workflow combined with the related information flow and management is necessary to understand the needs and problems in industrial processes. Therefore, the students have to learn not only about product data models but also about CAx-data exchange with actual standards like STEP. Detailed education in PDM/PLM normally exceed the frame of the limited curriculum, but special education should be offered for interested students, if the university has enough capacities.

9.2. Design knowledge

‘Design knowledge’ is not well defined, although it is of highest importance. Various aspects may be considered from the viewpoint of education:

- *Scientific design methodology.* Theoretical approaches as subjects of research. These areas are out of scope of CAx-education.
- Generic design methods and procedures developed to support real engineering work like concepts of

PahlandBeitz [5] or the directives of the VDI [6].

- CAx-design methods and procedures developed out of the capabilities of CAx-systems.
- Individual or team-internal experiences for design and fulfilling special engineering tasks. This field is closely related to the product or product part under consideration.

Especially the last three points are some kind of a knowledge base of an engineer. It should include also knowledge about the over-all product development process, and basics such as engineering components, primary functional principles, and recommended standard parts as well. Here the know-how return flow from industry is of importance.

This knowledge the students will learn through various standard lectures at the university about different subjects. In the context of an engineer’s education concerning CAx methods and procedures three different levels should be discussed in examples:

- ‘Parametric modelling’ [7], ‘Feature based design’ [8] are nowadays standard for modern CAx-systems and therefore also in CAx-education (although there are different understandings of ‘features’ in CAx-systems, the authors follow the definition of FEMEX [9])
- ‘Associative design’ is closely connected to the special product structures. Industrial companies often protect their know-how in this field against competitors.
- ‘Engineering in Reverse’ [10] is an holistic approach, which even some industrial researcher do not consider to be of importance in the near future although in some companies prototypes operate already. Such approaches go beyond standard CAx-education.

All these design methods and strategies are mainly ‘product driven’ although there are also roots in CAx-technology. From the viewpoint of the authors no side-neither the product development nor the CAx-technology can claim to be the originator of new design methods. It is always a cooperation.

Today ‘Concurrent engineering’ and ‘Simultaneous engineering’ are of central importance in industry. CAx methods supporting these strategies, like ‘Cooperative engineering’ or ‘CAx-conferencing’ can not be trained in praxis at most universities. But the students have to learn at least theoretically about them.

Design methods and procedures are not changing as fast as CAx-technologies. Nevertheless, it is an important topic in the curriculum of engineer students. These fundamentals are taught at the universities often by lectures teaching engineering sciences. But the aspects of CAx-technology have to be included. ‘Design knowledge’ can not be taught completely at universities, because in industrial life each company has its special necessities due to the kind of its product and has developed its own development strategy.

In industry the design methods and procedures are never used as formal as taught at universities. It is not subject of this paper to compare these approaches in theory and practice. Typical concepts are described by Pahl & Beitz [5] or in the VDI 2221 [6]. Both defined very formal design steps, but the industry has to follow internal and external constraints, e.g.: In automotive industry the ‘concept phase’, in which usually the functional principles are obtained, is restricted by the constraints caused by the ‘development platforms’. The aim of these development platforms is to increase the number of identical parts within different vehicles. The knowledge about these circumstances has to be gained on the job.

9.3. Practical training with CAX-systems

Practical training and work with a system by the student him/her self in front of a workstation is the standard for any CAX-education. It is not necessary to go into details, but a few aspects should be mentioned:

- The student should be taught—whenever possible—in more than one of the standard systems.
- From industrial point of view it is an advantage for the company if the student is trained at the university with the system, he/she will use in his/her job in the company.
- It is important that the student can work already at the university with a sequence of CAX-systems, e.g.:
 - CAD → CNC: producing a model of the part he/she designed
 - CAD → FEA: performing some calculations with the part he/she designed
 - CAS → CAD: Designing the shape of a product and learning about the difficulties to fulfil engineering requirements with it.
- Of importance are practical experiences in data exchange and also in PDM/PLM applications. Due to the limits in curricula they are often not taught.

9.4. Mathematical foundations

In the history of CAD there are various internal mathematical representations of geometry, elementary solid geometric elements and free form shapes:

- Concerning solids two representations are of interest: B-Reps and CSG (primarily only with primitive solids, nowadays also with B-Reps).
- Concerning free form shapes a few descriptions are important, all based on polynomial representation like Bézier-, ‘natural’-polynomials, B-Splines and NURBS.
- Additional surface descriptions by point clouds or/and by very dense facets are used for visualisation or CNC-milling.

All CAX-system kernels use some of these representations for basic CAX-functionalities. The necessary internal

mathematical algorithms using these representations are mostly protected intellectual property and are normally not of interest for the CAX-user. But the users have to be interested in the ‘quality’ of the results.

As already mentioned nowadays additional to the ‘classical’ CAX-functionalities (like e.g. ‘surface–surface intersection’), parametric geometry, variational design and associative relations between various geometries are state of the art. But in what detail does mathematics have to be taught in CAX-education? From our point of view generally any person related to CAX should be taught some knowledge of mathematical fundamentals:

- An overview of the various mathematical representations including their advantages and disadvantages, possibilities, the degree of freedom in design, but not the formulas themselves.
- An overview of algorithms of functionalities and design procedures. Of interest are the logic, the philosophy, the possible problems, the advantages and disadvantages and the quality of the used numerical methods. Again formulas of the mathematical algorithms themselves are not of particular interest.

The aim is to make students or future engineers able to judge how reliable a result calculated by a CAX-system is and which specific application problem might be caused by the mathematical representation. Of course the mathematical knowledge usually taught at the universities is not sufficient for all CAX-related jobs. People like CAX-software developers or engineers for CAX-application tools need much more in-depth knowledge. But where do these people get this knowledge from? This in-depth mathematical knowledge has to be imparted by the industry or software house. There are various alternatives again:

- Within the company there are already experienced experts, who did research on this subject in the past, e.g. at universities. These specialists could teach the younger colleagues.
- The company could employ specialists as temporary teachers from universities or research institutes.
- The company could send the selected employees to special seminars or internships at a university or research institute.

Thus, the teaching of particular in-depth mathematical knowledge again is a task of the universities. But it is not part of the standard CAX-education curriculum.

9.5. IT-knowledge

Standard IT-knowledge has to be trained at universities. This knowledge should be sufficient for the standard CAX-user or CAX-manager. Nowadays anybody, not only

CAX-concerned people, should be familiar with this technique. Further in-depth IT-training within CAX-education at universities is not really reasonable due to some problems:

- The modern IT-world is changing very fast. Specialist knowledge, which would be trained at universities, would be out-of-date even before the student would have left the university.
- In industry there are many different platforms hard- and software configurations, each of them requiring different knowledge. On which platform, on which hard- and software should the students be trained?

It is the job of the universities to give an overview of the up-to-date hard-and software configurations and to make students aware of opportunities, which are connected to them. An example might be the potentialities and problems of the Application Programming Interfaces (APIs), which are usually parts of the standard CAX-tools:

- APIs on one hand offer users the opportunity to extend their in-house systems to solutions of specific problems. Via API most of the standard CAX-functionalities can be used within a 3rd-party-SW-module written for a specific problem for a special customer.
- On the other hand API-programming is a very difficult task and very often the API is not documented very well. Additionally the API might be changed by a software vendor during a release change, with the effect that 3rd-party programs may not run anymore.

All this very special CAX-related IT-know-how can only be learnt in high level seminars or courses, performed from the specialists of SW suppliers or well experienced 3rd-party vendors. This is out of the scope of university teaching.

A special field belonging to IT is 'Computer graphics'. Some fundamentals of this subject should be taught in the frame of CAX fundamentals.

9.6. Selection of CAX-systems for CAX-education at universities

The decision which CAX-Systems should be used for education at universities is not as complex as the selection of a CAX-system for a company. From our point of view in the beginning of the CAX-education a standard midrange system should be used. The system vendor should give any student the opportunity to install a version at his/her home PC for a very low price. In the main study period the students should be able to handle one of the popular high-end systems. Additionally it would be an advantage, if they could have access to other systems of the market, if they want to. Some aspects should be discussed:

- Modern CAX-systems are very complex and even in industry no one really knows and uses all of the delivered functionalities. Depending on the branch and the project about 15–20% of its capabilities are used. For standard CAX-education at universities there is no chance trying to teach the students the whole functionality of one or more systems. But they should get a more or less broad overview, so that the students can understand the philosophy, which is behind the systems. For a special application field he/she may go more in-depth.
- The common CAX-systems such as CATIA-V5, Uni-graphics and Pro/Engineer are not very different in the look and feel. Thus for CAX-education one systems is as good as the other. Thus, being taught the use of one system, the student should be able to get used to any other system very quickly.
- Usually the time, which is planned in the curriculum for CAX-education is too short to guarantee a broad CAX-education. Until there will be a shift from classical engineering to modern CAX-integrated design, the students have to enlarge their knowledge voluntarily.
- Often industrial companies ask for engineers being taught at the university the same system as used by this company. From our view point a student should be taught another system at the university: later on in his/her job the mind of the engineer will be more flexible and not limited by the capabilities of the only system.

To sum up, one or two systems for the basic and advanced education is enough, but it is vital that students can enlarge their knowledge by having access to other systems, if they want to. Any standard CAX-system can be used in CAX-education, the decision depends on the provided support from the vendors and expertise on the different systems at the university. The price, the needed capacities for maintenance and-last not least-the availability of the system for the student at home are further aspects.

10. Conclusion

The modern product development gets more and more complex and is a part of the product lifecycle. CAX-technologies are completely integrated. Therefore, product development can not be seen on its own, as CAX and CAX-education can not be considered stand-alone. Historically CAD was in the focus. Nowadays a network of various CAX fields is supporting quite different tasks and occupational profiles in product development and manufacturing.

Therefore CAX education has to be considered in this paper, this may be summed up in some statements:

- CAD is only a part of CAX. CAX engineering is an integrated part of modern product development and manufacturing.

- There is not any precise job profile for engineers in industry. Mechanical engineering is connected to many different technical/scientific disciplines. Most professions are related to CAx in some kind.
- To think about one broad CAx-education is fiction. CAx education always has to be tailored to a specific group of persons and/or jobs.
- CAx education has two bases: Universities and free industrial enterprises.

University aspects:

- Universities have to teach the CAx-basics and design methodology to all students. It is in the responsibilities of the students to enlarge their knowledge in certain areas. Universities have the duty to offer opportunities to the students to get specialist knowledge in a broad range of subjects.

Industrial aspects:

- The human potential is the most important field of investments, the education of the employees is a key for a long term companies success.
- Companies have to take care of specialised CAx-education for their employees. They can not expect to get completely trained employees for their specific tasks in a special system.

Human aspects:

- New CAx-oriented design methodologies like ‘associative modelling’ will create new job profiles.
- Fluctuation of people within short time is standard nowadays: moving from operational activities into coordination/management positions. Or changing the branch: moving from product related departments to CAx-/IT-technology related fields.
- Individuals become more and more responsible for their own CAx-education. Students will need to find their own field of interest, where they need to gain specialist knowledge in order to be competitive on the job market.
- The effort for CAx-education and the related expenses have one reason in the complexity of the tool-the CAx-systems. In the future we expect, that psychological aspects will come to the foreground, the human way of thinking and communicating will be the guideline for new system development. Some attempts were already done by using terms of the language to control and modifying shape design [11].

Although we are convinced of the importance of modern IT-based techniques, we should not forget the way, how we had come to the present level of technology: In analogy to the evolution theory of Charles Darwin we may remember, that in the evolution of any individual there are many

components/aspects of the evolution of the history before this person. We should not completely forget the classical methods and experiences of engineering work in the last century, which may be a part of the education of a modern IT-oriented engineer.

Generally spoken the rapidly changing product development shifts more and more into the virtual world. This requires high flexibility from all people involved. Universities and companies will need to react on new trends in the product development, they have to adapt to these trends and offer new training methods. This ability of the companies and of the universities will be crucial for their competitiveness. The ability of an individual to adapt to new trends and technologies as well as the volition to gain new knowledge will be crucial for his/her personal success on the job market.

Acknowledgements

The authors would like to thank their colleagues from German Automotive Industry very much for many informative discussions. Special thanks is given to the enterprises S + W CA-Technik GmbH, which let us share in their experience in industrial CAx-training, and with UNICO MEDIA GmbH, which provides the CBT Package ‘Surf & Learn’ and discussed with us openly the success of CBT in combination with conventional training.

References

- [1] Solid works in education: newsletter: the learning curve, Winter/Spring; 1999.
- [2] Summarised by using information for Alessi, BMW, PININFARINA; Saab.
- [3] Friederici G. CAD-CAM-Report 2004;1:34.
- [4] Poitou JP. University de Provence/Laboratoire de Psychologie Cognitive, Université de Provence. Private communication; 2004
- [5] Pahl G, Beitz W. Engineering design, 2nd ed. Berlin: Springer; 1999.
- [6] VDI 2221: Methodik zum Entwickeln und Konstruieren technischer System und Produkte. VDI-Verlag GmbH Düsseldorf; 1986
- [7] Hoschek J, Dankwort W, editors. Parametric and variational design. Stuttgart: Teubner; 1994. Roller D. CAD-Effiziente Anpassungs-und Variantenkonstruktion. Berlin: Springer; 1995.
- [8] Shah JJ, Mäntylä M. Parametric and feature-based CAD/CAM. New York: Wiley; 1995.
- [9] FEMEX: Working Group, Feature modelling experts. J Ovtcharova 1995–1997; Weber C. What is a feature and what is its use?-Results of FEMEX Working Group. In: Proceedings of 29th International Symposium on Automotive Technology and Automation (ISATA 96); 1996. p. 109–16
- [10] Werner DC, Karl-G F. Engineering in reverse—a holistic extension of CAD. In: Papers of the workshop, New Trends in Engineering Design, Balatonfüred, Hungary; 2003. p. 91–4.
- [11] FIORES-II. Character preservation and modelling in aesthetic and engineering design. Project of the European Community Growth No. GRD1-1999-10785; 2000–2003.



C. Werner Dankwort is professor of the University of Kaiserslautern in the Department of Mechanical and Process Engineering since April 1994. Holding the chair for Computer Application in Engineering Design, he is responsible for CAD/CAM teaching and research. In 1966 Prof. Dankwort obtained his PhD in physics at the University of Bonn in 1972. After Postdoc research he joined the technical-scientific data processing of BMW. From 1986 to 1994 he was manager of CAD/CAM Support in the car body design department. Prof. Dr Dankwort was engaged in the working group of the German Automotive Industry Association (VDA) for CAD/CAM data exchange (VDAFS) and is now moderating the working group 'CAD/CAM Strategies of the German Automotive Industry'. Topics of his research activities are CAD/CAM Strategies, Interoperability of CAX-systems, Engineering in Reverse in Aesthetic Design (European projects).



Roland Weidlich is scientific assistant at the working group 'Computer Application in Design' at the University of Kaiserslautern since 2002. Followed by a Diploma Thesis at DaimlerChrysler Germany and DaimlerChrysler USA he received his Master of Mechanical Engineering at the University of Kaiserslautern in 2001. At the working group he is in charge of the practical CAD-courses and the maintenance and support of the installed CAD-systems. His field of research are Engineering in Reverse and Design Formalisms.



Birgit Günther is scientific assistant at the working group 'Computer Application in Design' at the University of Kaiserslautern. She received her MSc in techno-mathematics at the University of Kaiserslautern in 2001. Already during her studies she held professional courses for CATIA V4 in industry. She was first in charge of the administration of the late phase of the European project FIORES-II and at the moment she is supporting CAD education. Her fields of interest is the methodology of CAD systems, esp. CATIA, as well as CAD-training in general at university and industry.



Jörg Blaurock is scientific assistant at the working group 'Computer Application in Design' at the University of Kaiserslautern. He received his BSc at TU Darmstadt in 1988 and his MSc at the University Karlsruhe in 1993, both in Mechanical Engineering, followed by further studies at the universities of Freiburg and Munich. Since 1996, he has been in charge of practical courses, theoretical exercises and examinations. He also participated in the European project FIORES-I. His field of research is the haptical presentation of surfaces modelled with CAD systems. His research interests also include the evolution of the graphical user interface of CAX-systems and Virtual Reality.